

# GENERAL FITTING GUIDE - COUNTERTOP SUPPORT BRACKETS

(PRODUCT SHOWN WILL VARY DEPENDING ON MODEL)

1

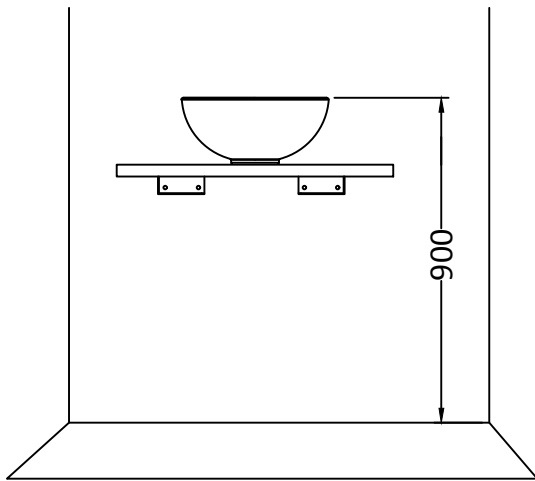

RECOMMENDED INSTALLATION HEIGHT.

2

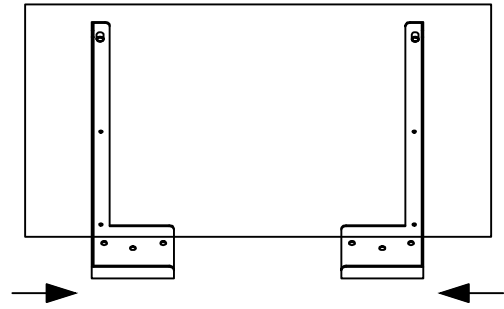

INSET SUPPORT BRACKETS FROM EACH EDGE TO REDUCE VISIBILITY ONCE INSTALLED.

3

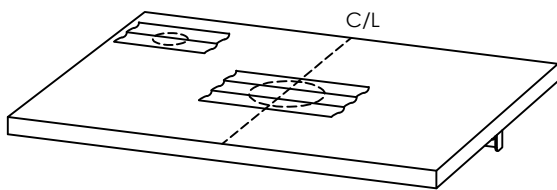

APPLY MASKING TAPE OVER THE AREAS TO BE CUT TO AID MARKING OUT AND PREVENT DAMAGE TO THE SURFACE. CUT SUITABLE APERTURE FOR THE BRASSWARE AND PLUMBING, MAKING SURE THE CUT OUT IS NOT VISIBLE WHEN THE BASIN IS IN PLACE.

4

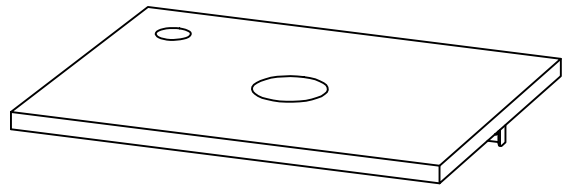

ALL CUT EDGES MUST BE SEALED FULLY WITH A SUITABLE SEALANT. FAILURE TO DO THIS WILL INVALIDATE THE WARRANTY.

5

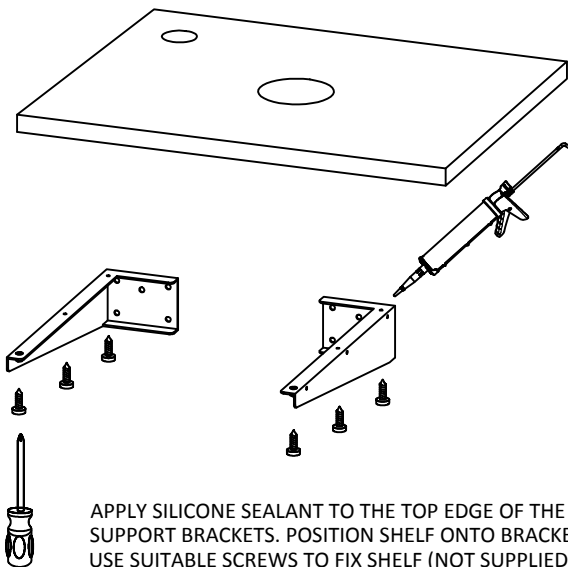

APPLY SILICONE SEALANT TO THE TOP EDGE OF THE SUPPORT BRACKETS. POSITION SHELF ONTO BRACKETS & USE SUITABLE SCREWS TO FIX SHELF (NOT SUPPLIED)

6

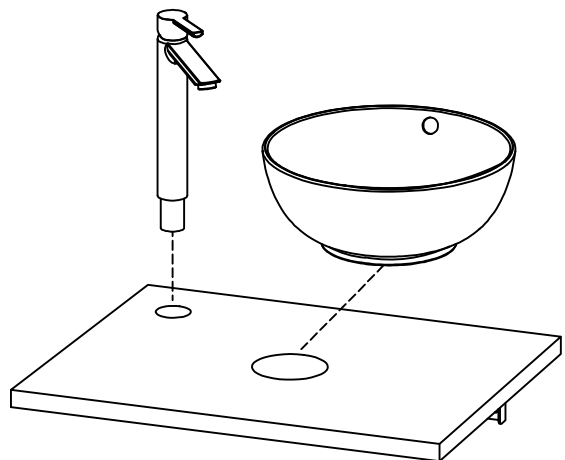

FIT THE BASIN WASTE, MAKING SURE THERE'S A GOOD SEAL. FIT ANY BRASSWARE AND CONNECTIONS IF REQUIRED AT THIS POINT. APPLY A BEAD OF SILICONE AROUND THE BASE OF THE BASIN THAT WILL BE IN CONTACT WITH THE WORKTOP. PLACE THE BASIN IN POSITION ON THE WORK SURFACE AND PRESS DOWN TO MAKE A SEAL. CLEAN OFF ANY EXCESS SEALANT